



This PDF is generated from authoritative online content, and is provided for convenience only. This PDF cannot be used for legal purposes. For authoritative understanding of what is and is not supported, always use the online content. To copy code samples, always use the online content.

SIP Cluster Solution Guide

Configuring GWS

Contents

- 1 Configuring GWS
 - 1.1 Identification
 - 1.2 Deployments
 - 1.3 Provisioning

Configuring GWS

Web Services and Applications (formerly Workspace Web Edition & Web Services) is a set of REST APIs and user interfaces that provide a web-based client interface to access Genesys services. Web Services and Applications (GWS) supports SIP Cluster with some limitations.

Identification

To identify if the environment is a SIP Cluster, GWS checks if the CloudCluster connections have the **server-role** setting as 5. Once identified, a **GET ../api/v2/genesys-environments/{id}?fields=*** will return the **clusterMode** flag enabled in the response and the Employee login can be used as the agent login.

```
"voiceEnvironments": [
{
  "backupAddress": "%backup_address%",
  "backupDbid": 371,
  "backupPort": "5001",
  "backupServerName": "SIPS_B",
  "backupSipPort": "5060",
  "clusterMode": true,
  "connectionProtocol": "addp",
  "id": "53ef36a3-e10d-45cc-82dd-16db9a600fb1",
  ...
  "tserverConnections": [
  {
    "backupAddress": "%backup_address%",
    "backupDbid": 371,
    "backupPort": "5001",
    "backupServerName": "SIPS_B",
    "backupSipPort": "5060",
    "connectionProtocol": "addp",
    "genesysEnvironmentId": "2ad2a3b5-5f8a-47b0-b196-7465b959416e",
    "id": "6e35d741-db06-4eae-a95f-743c5ef4fe83",
    ...
  }
  ]
}
...
}
```

The **useEmployeeIdAsAgentLoginForSIPCluster** option in the **application.yaml** file must be set to **true**. This setting enables the employee ID to be used as the agent login. The **StartContactCenterSession** call will use the employee ID as the login ID.

Deployments

In a SIP Cluster deployment, WWE is the agent-facing UI and Genesys Softphone is the software SIP Endpoint. There are two possible deployments that GWS supports for SIP Cluster:

- Standalone mode
- Connector mode

Standalone Mode Deployment

In a Standalone deployment, WWE and Softphone run side-by-side in the same data center. The settings for the Softphone including REGISTER URI (including a DN), are shipped with binaries in a configuration file.

Connector Mode Deployment

In a Connector deployment, WWE configures and controls Softphone during runtime. The settings for Softphone is identical in all instances and the configuration is centralized in the configuration environment (including a DN).

Provisioning

To support SIP Cluster, the following items have to be provisioned.

Person	<ul style="list-style-type: none">• For Standalone Mode, the defaultPlace is not required for hot seating.• For Connector Mode, the defaultPlace is required for hot seating. <p>The Employee ID is used as the AttributeAgentID in TAgentLogin requests when the useEmployeeIdAsAgentLoginForSIPCluster option is set to <i>true</i> in the application.yaml file.</p> <p>Extension DNs are configured under the SIP Cluster switch.</p>
Place	The Extension DN must be configured.

The Agent Login objects should not be configured in the SIP Cluster environment.

GWS Connection to 4-node 2-DC SIP Cluster

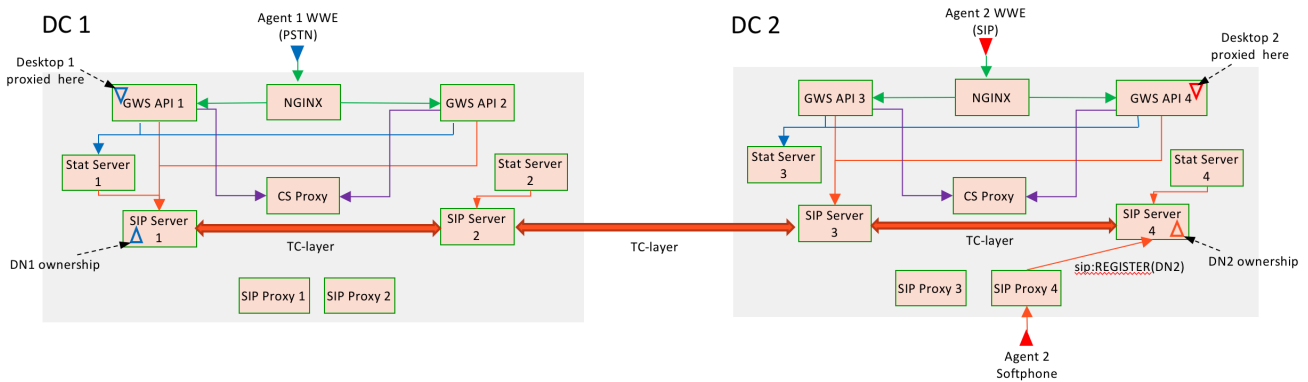

All GWS API nodes in one data center connects to:

- one SIP Cluster node
- one Stat Server
- Configuration Server Proxy

All connections have the **locations** parameter specified in the **Application Parameters** section of the **Advanced** tab:

- locations=/APS3

See [Multiple Data Center Deployment](#) for more information on configuring multiple data centers.

SIP Access Point Configuration

Ensure the following items are configured:

- All SIP traffic to SIP Cluster should be sent to one geo-aware SRV FQDN address, e.g., sipcluster.abc.com.
- The SIP Cluster access point SRV FQDN is configured in the **SIP Outbound Proxy DN** of type Voice over IP Service as a value of the **external-contact** parameter in the **[TServer]** section.
- SIP Cluster sends this FQDN as its contact in the outgoing SIP messages. e.g., Record-Route: sipcluster.abc.com
- All SIP clients of the SIP Cluster must support the SRV FQDN and should be able to resolve the SIP Cluster access point SRV FQDN:
 - RM, SBC, Softphones
- **DNS records** should be configured to resolve the SRV FQDN to the SIP Cluster access point closest to the requestor.
- SIP Cluster access point may be SIP Proxy, or SBC, or both.

WWE Provisioning for Softphone

Configure Genesys Softphone with the following patterns, *privilege.sipendpoint.XXX*:

- privilege.sipendpoint.can-use
- privilege.sipendpoint.can-change-microphone-volume

Control Parameters

<p>Softphone Control Parameter</p>	<ul style="list-style-type: none"> • sipendpoint.uri: http[s]://localhost:<softphone-listening-port> <p>Ensure that the protocol is aligned with the GWS browser connection protocol (http or https).</p>
<p>SIP Configuration Parameters</p>	<ul style="list-style-type: none"> • sipendpoint.sip-server-address: SRV FQDN pointing at the SIP Cluster SIP access point, e.g., sipcluster.abc.com • sipendpoint.transport-protocol: udp/tcp/tls
<p>Softphone Specific Parameters</p>	<p>Based on the pattern: <i>.<domain>.<section>.<setting></i>, all parameters in this category are automatically sent to the Softphone. The Softphone overwrites local configuration file settings with the values received from the connector:</p> <ul style="list-style-type: none"> • sipendpoint.policy.device.use_headset=1 • sipendpoint.policy.device.headset_name=*