



This PDF is generated from authoritative online content, and is provided for convenience only. This PDF cannot be used for legal purposes. For authoritative understanding of what is and is not supported, always use the online content. To copy code samples, always use the online content.

Web Services and Applications Deployment Guide

Architecture

Contents

- 1 Architecture
 - 1.1 Large deployment
 - 1.2 Medium Deployment
 - 1.3 Small Deployment
 - 1.4 GWS Platform Service-only Deployment
 - 1.5 High-Availability Model for Web Services deployments

Architecture

This page describes the standard deployment architectures for Genesys Web Services (GWS) 8.6.

GWS comprises of the following three software components:

1. **GWS API Service** - can be configured through a configuration option to perform the following roles:
 1. **API Processing** - handles all API requests from Workspace Web Edition (WWE) or Custom Desktop Applications.
 2. **Configuration Indexing** - populates Elasticsearch with configuration information to support searches by WWE or Custom Desktop Applications.
 3. **Statistics Indexing** - populates Elasticsearch with statistical information to provide statistics to WWE or Custom Desktop Applications.
 4. **WWE Static Content** - provides the UI web content for WWE.
2. **GWS Platform Service**
 1. Configuration API
 2. Outbound API
3. **Agent Desktop Package** - WWE Static Content is provided as a separate package to install on Load Balancer for improved scalability.

Important

Nearly all GWS/WWE deployments require Elasticsearch for providing statistics and search capabilities within WWE. For deployments which use only GWS APIs for custom desktop applications, if the API usage does not invoke APIs that trigger Elasticsearch usage, then GWS can be deployed without index nodes and without Elasticsearch. If your deployment type belongs to this model, then consult with Genesys support.

Large deployment

1. For maximum scalability and resiliency, the Web Services components are deployed on different nodes as described in the diagram below.
2. GWS API Service with API processing role operates with N+1 High Availability (HA).
3. GWS API Service with Configuration Indexing role operates with 1+1 High Availability (HA).
4. GWS API Service with Statistics Indexing role operates with 1+1 High Availability (HA).
5. GWS Platform Service operates with N+1 High Availability (HA)
6. WWE Static Content Service is deployed on Load Balancer

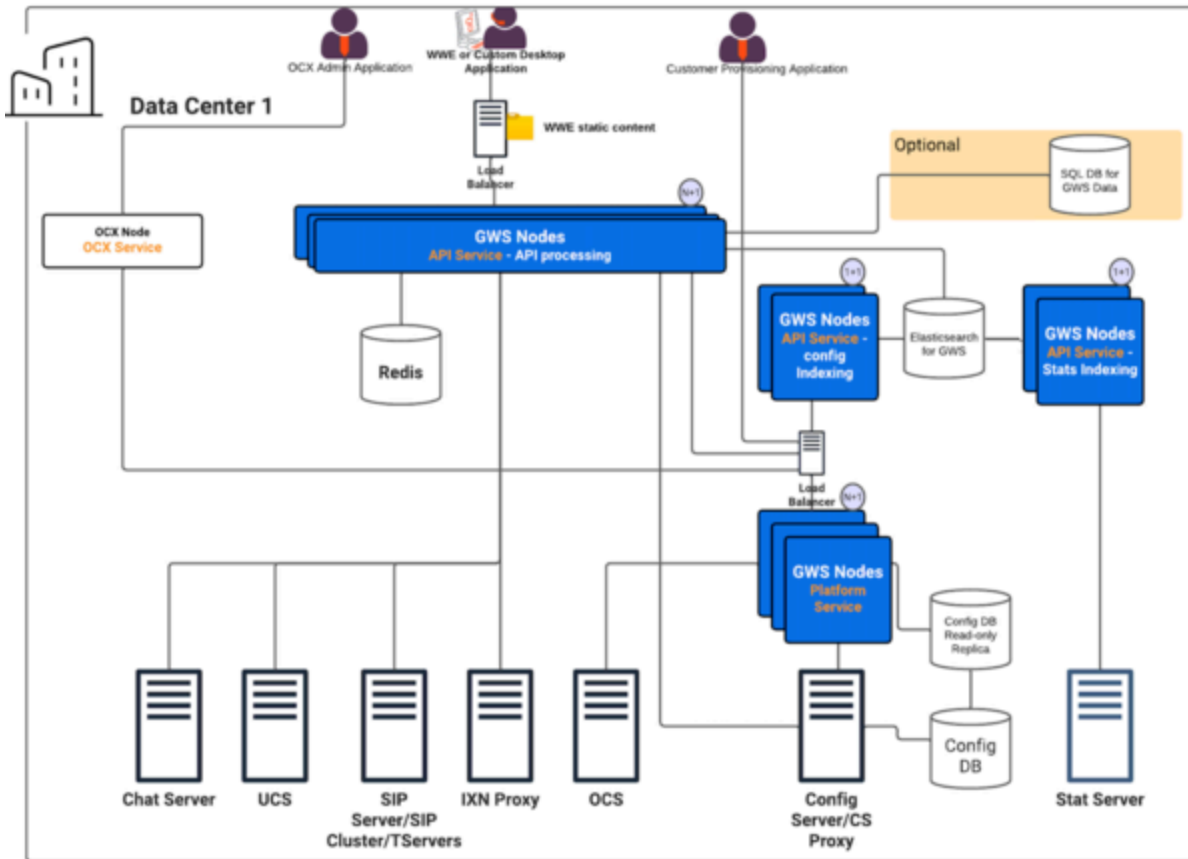

To optimize the hardware resource usage, the following are additional deployment references:

Medium Deployment

1. GWS API Service with API processing role operates with N+1 High Availability (HA).
2. GWS API Service with Statistics Config Indexing role operates with 1+1 High Availability (HA).
3. GWS API Service with Statistics Indexing role operates with 1+1 High Availability (HA).
4. GWS Platform Service operates with N+1 High Availability (HA)
5. WWE Static Content Service is deployed on Load Balancer

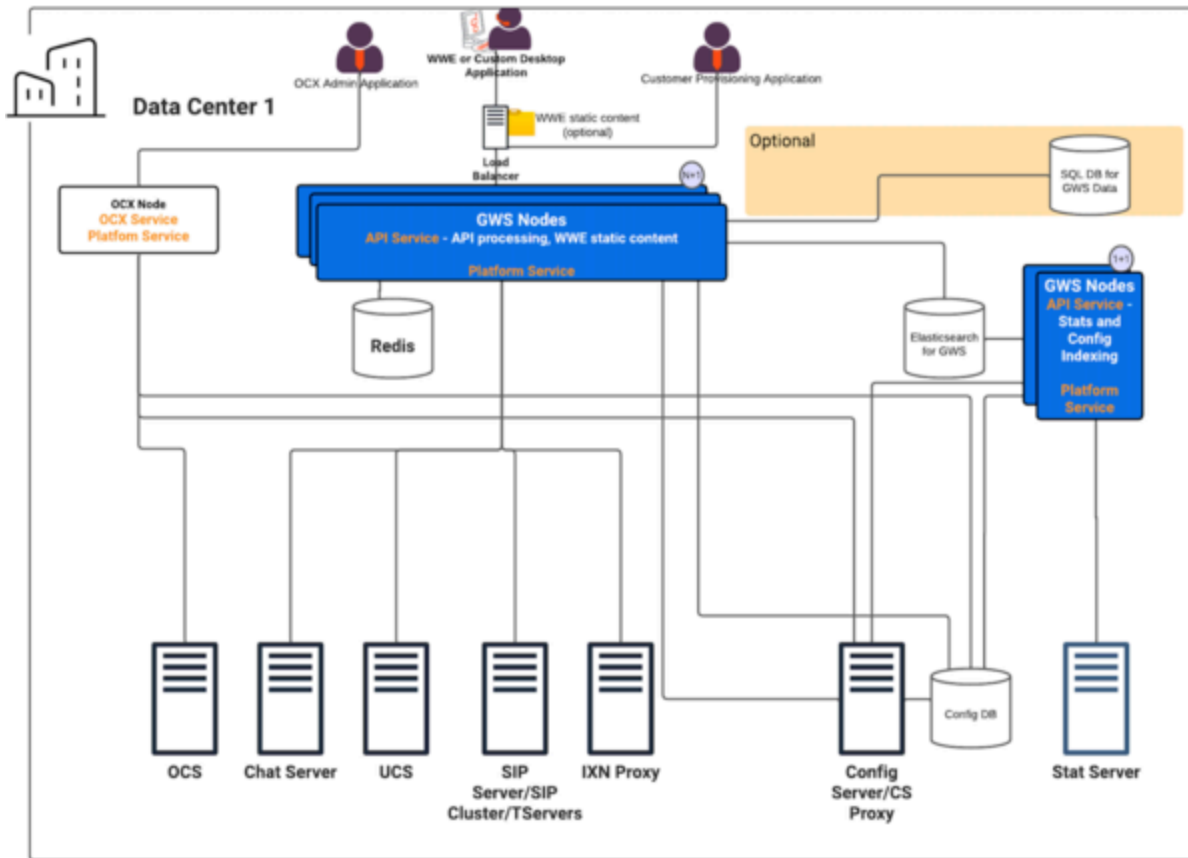

Small Deployment

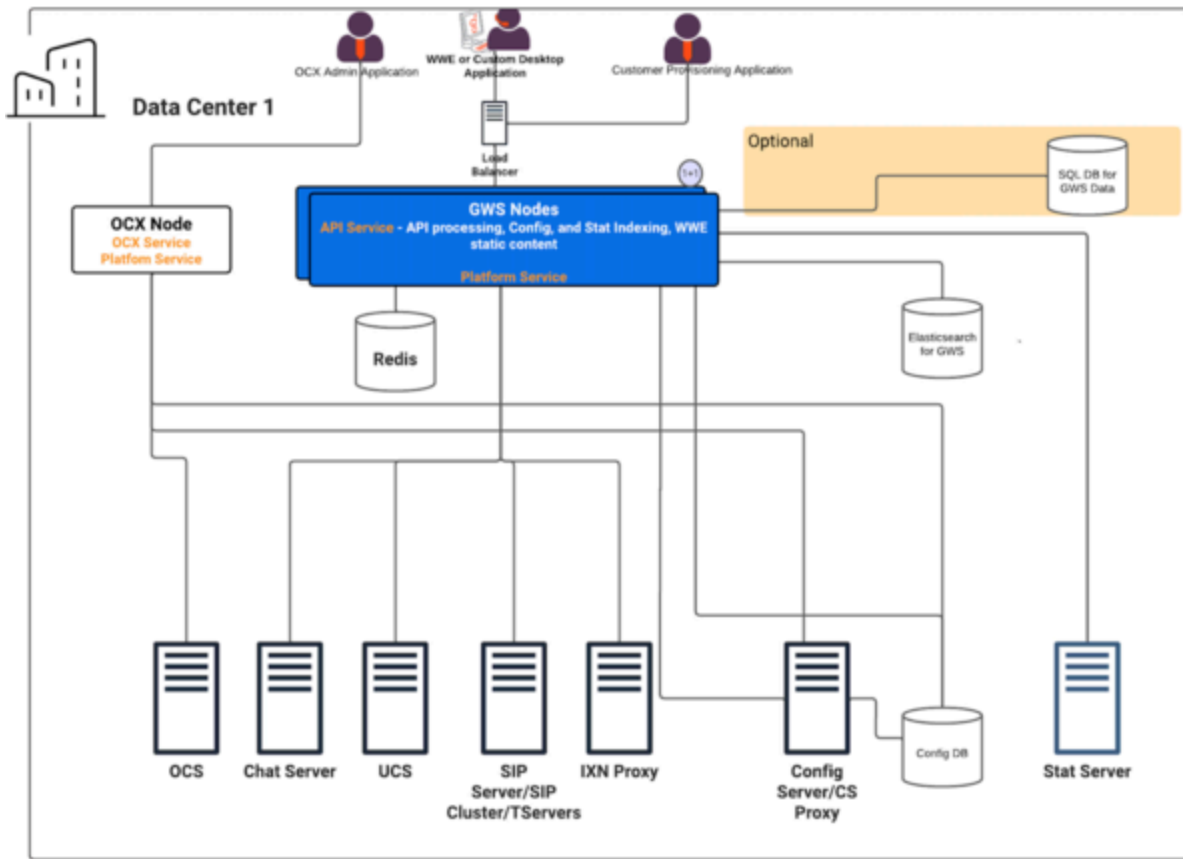

GWS Platform Service-only Deployment

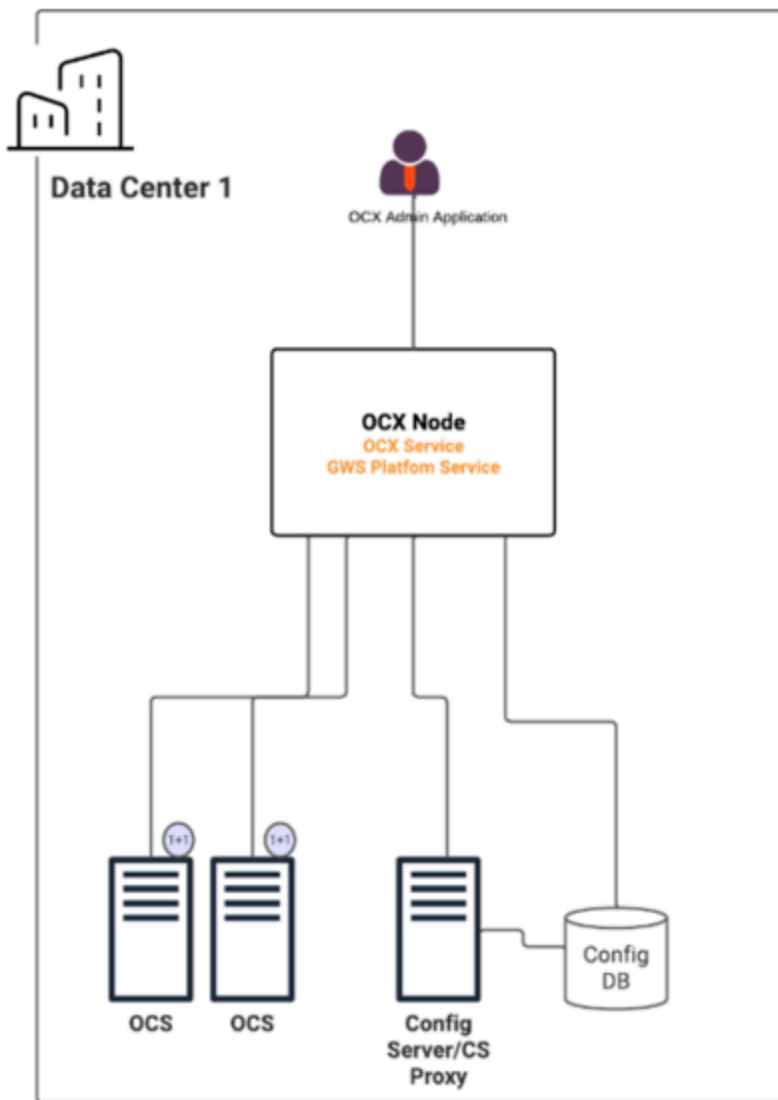

This low-footprint deployment model is recommended when GWS 8.6 is required only in support of Outbound Contact Expert (no WWE Agent Desktop or custom agent desktop).

High-Availability Model for Web Services deployments

1. GWS Index nodes may be deployed in one of two ways:
 1. GWS Index nodes deployed in 1+1 HA, node configured to perform indexing of both configuration and statistics. Intended for deployments of fewer than 5,000 agents.
 2. GWS Index nodes deployed in two pairs of 1+1 HA, with one set configured to perform indexing of configuration, the other set configured to perform indexing of statistics. Intended for deployments of 5,000 agents and larger

2. The GWS SQL Database is optional. It supports storage of Custom Contacts and Custom Settings persistent settings - if these features are not utilized, then database is not required.
3. GWS 8.6 offers the following voice infrastructure support: SIP Server, SIP Cluster, and three T-Servers: Avaya, Cisco, Alcatel