



This PDF is generated from authoritative online content, and is provided for convenience only. This PDF cannot be used for legal purposes. For authoritative understanding of what is and is not supported, always use the online content. To copy code samples, always use the online content.

Genesys Info Mart User's Guide

IVR-Behind-Switch Call Flows

Contents

- 1 IVR-Behind-Switch Call Flows
 - 1.1 Inbound to IVR via ACD queue
 - 1.2 Inbound to IVR directly
 - 1.3 Mute transfer to ACD queue
 - 1.4 Mute transfer to agent

IVR-Behind-Switch Call Flows

This page illustrates inbound voice call flows that are available in IVR solutions where the IVR is deployed behind the switch.

Voice interactions that arrive at the switch are queued to an ACD queue, where the ACD positions are actually IVR DN's. Either self-service, or simply front-end identification and segmentation, can be the focus of the IVR application. If the IVR application cannot completely handle the voice interaction, the interaction can be transferred to an ACD queue that represents a requested skill, service type, or customer segment. Agents who are logged in to the ACD queues handle the interactions.

The following IVR-behind-switch call flows are supported:

- **Inbound to IVR via ACD queue**
- **Inbound to IVR directly**
- **Mute transfer to ACD queue**
- **Mute transfer to agent**

Inbound to IVR via ACD queue

In this call topology, the interaction arrives at the ACD queue and is diverted to an IVR DN. The following diagrams illustrate two possible outcomes:

- **Inbound to ACD queue completes normally (self-service IVR)**
- **Inbound to ACD queue is abandoned by the customer (nonself-service IVR)**

Inbound to ACD queue (self-service IVR) — Call completes normally

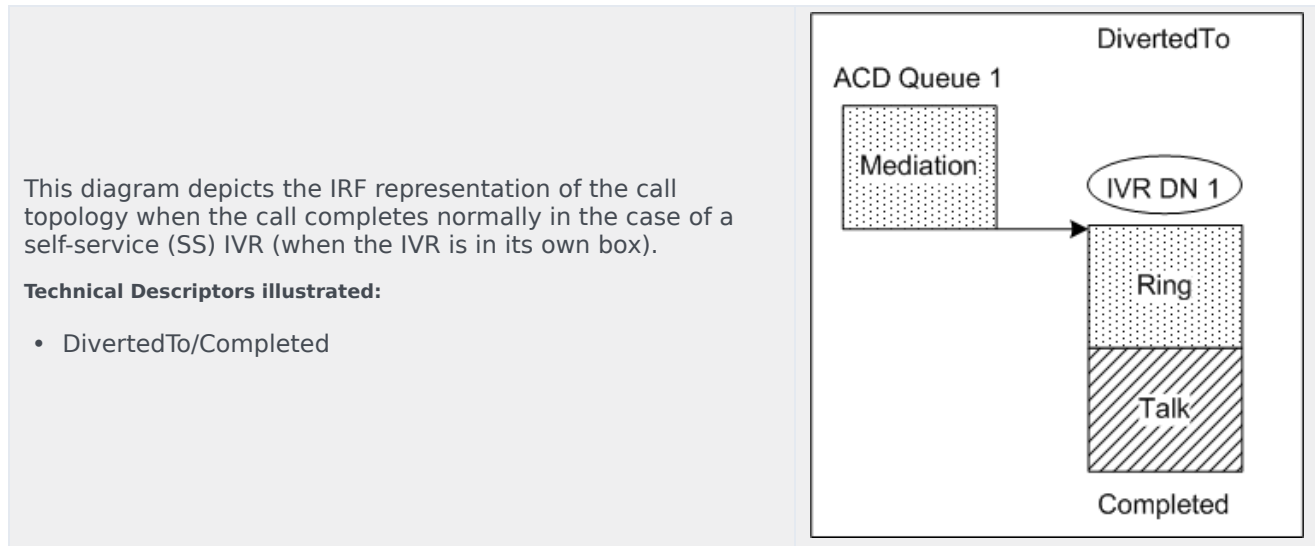

Inbound to ACD queue (nonself-service IVR) — Call abandoned by customer

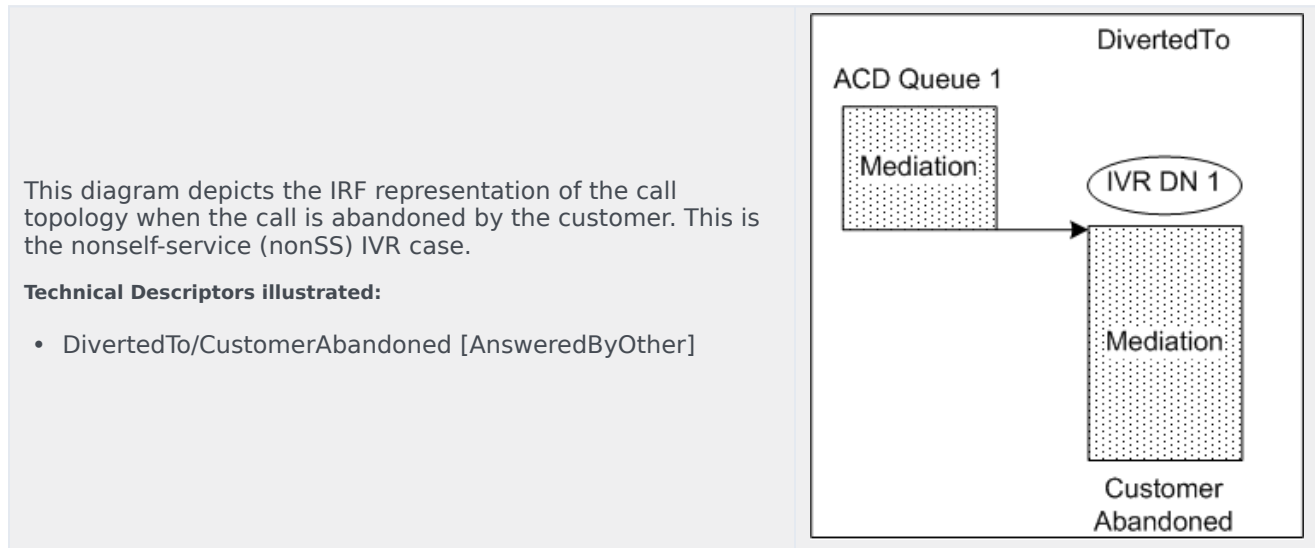

Inbound to IVR directly

In this call topology, the interaction arrives directly at an IVR DN. The following diagrams illustrate two possible outcomes:

- Inbound to IVR completes normally (self-service IVR)
- Inbound to IVR is abandoned by the customer (nonself-service IVR)

Inbound to IVR (self-service IVR) — Call completes normally

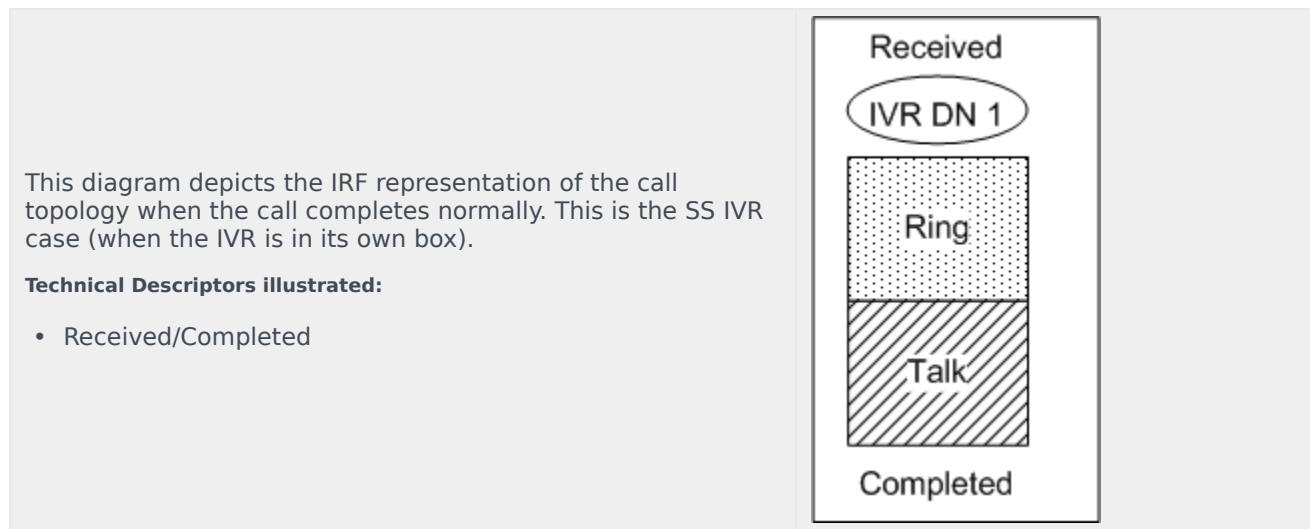

Inbound to IVR (nonself-service IVR) — Call abandoned by customer

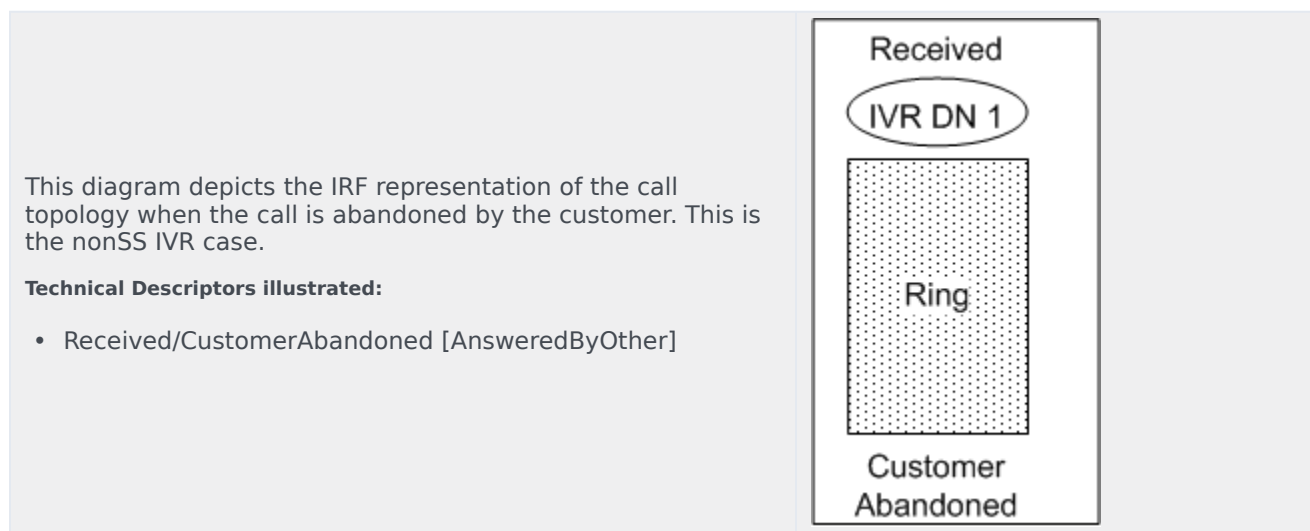

Mute transfer to ACD queue

In this call topology, the interaction is mute transferred to an agent via an ACD queue. The interaction arrives at an ACD queue and is diverted to an IVR DN. The IVR then mute transfers the call to another ACD queue. The following diagrams illustrate two possible cases:

- Mute transfer to ACD queue from a self-service IVR
- Mute transfer to ACD queue from a nonself-service IVR

Mute transfer to ACD queue — Self-service IVR

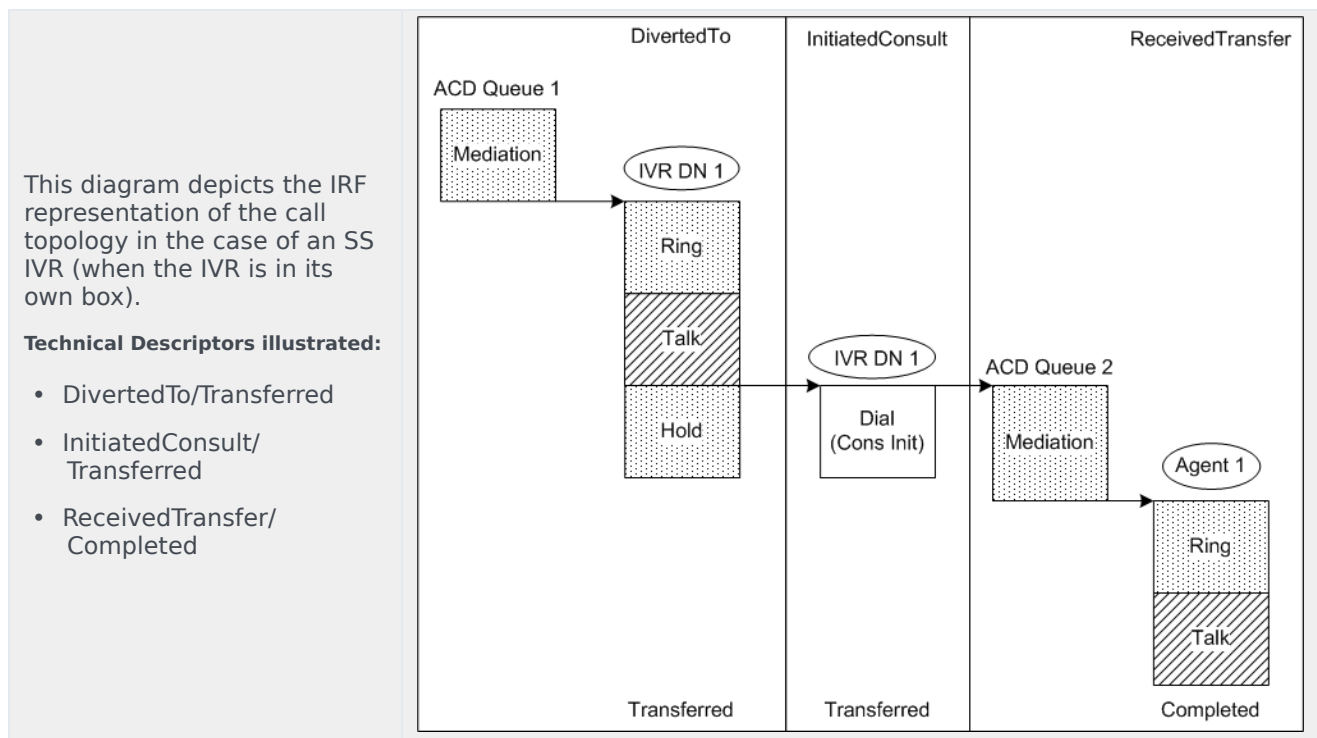

Mute transfer to ACD queue — Nonself-service IVR

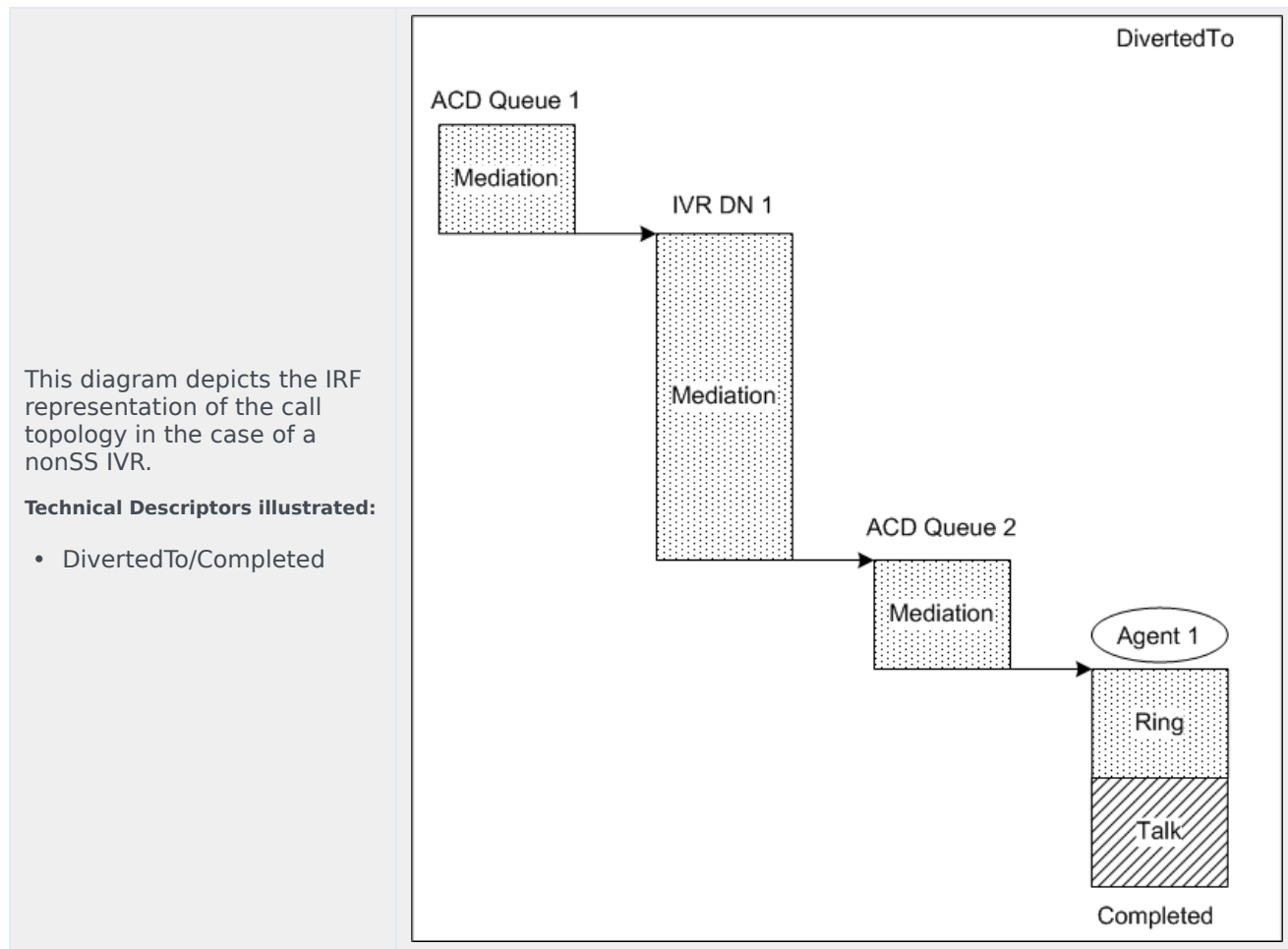

Mute transfer to agent

In this call topology, the interaction is mute transferred to an agent. The interaction arrives at an ACD queue and is diverted to an IVR DN. The IVR then mute transfers the call to an agent. The following diagrams illustrate two possible cases:

- Mute transfer to agent from a self-service IVR
- Mute transfer to agent from a nonself-service IVR

Mute transfer to agent — Self-service IVR

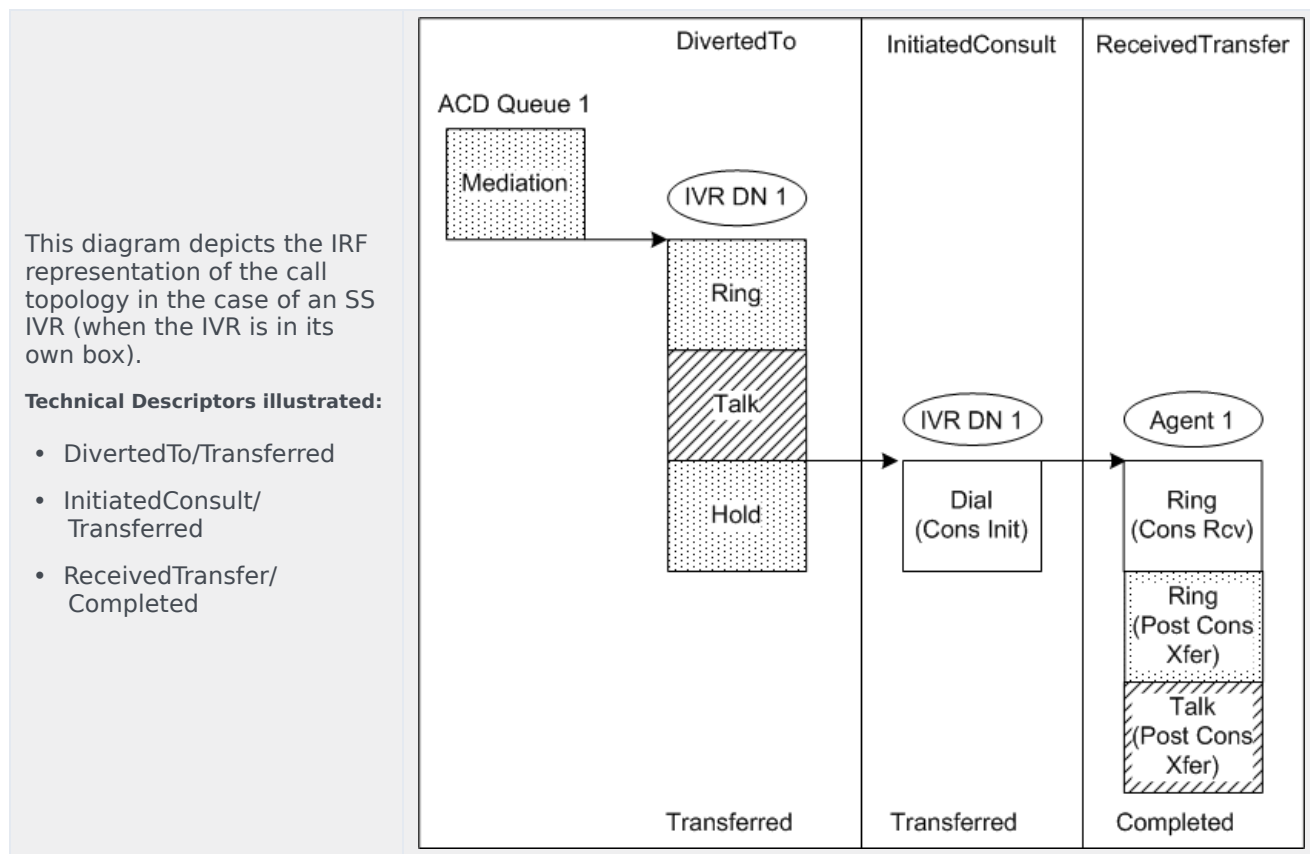

Mute transfer to agent — Nonself-service IVR

